



ARC Audio  
4719 Greenleaf Cir. #4  
Modesto, CA 95356  
Ph. 209-543-8706

## SPEAKER SPECIFICATIONS AND PARAMETERS

---

[WWW.ARCAUDIO.COM](http://WWW.ARCAUDIO.COM)

# *BLACK*

# *COMPONENT SYSTEM*

Table of Contents	
Introduction	2
BLACK Crossover Features	3
Crossover Jumper Settings	4
Crossover Jumper Locations	5
System configurations	
2-Way System	6
2-Way Bi-Amplified	7
3-Way System	8
Crossover Schematics	9
Specifications	
BLACK 4.0	10
BLACK 5.0	11
BLACK 6.0	12
BLACK 1.0	13
Warranty	14

# ***INTRODUCTION***

The attributes and documented success of a high end company doesn't stop with one line of product.

With the defined success and merit of the ARC Audio Signature Edition amplifier line by Robert Zeff ARC Audio has joined forces with some of the worlds leading pro audio speaker engineers to develop and introduce the ARC Audio Black Series.

The Black Series speaker line is designed with focus placed on transparency, performance and natural reproduction of music the way it was intended to be heard. With over 27 years of audiophile speaker engineering design behind this line the Black Series offers only the purest, smoothest and most dynamic un-timbered sound available in the car audio industry ultimately creating the finest audiophile speaker to ever hit the car audio market.

The ARC Audio Black Series speaker system delivers users an exceptionally reliable no compromise design with every consideration taken in choosing only the finest and most advanced acoustical materials available for such a prestigious speaker offering. From hand picked , a 5 stage quality control and speaker testing process including Visual, loaded and unloaded dynamic frequency response testing, mechanical parameter verification, and musical response testing and ARC Audios exclusive speaker matching process the Black Series speaker line will give you the finest resolution and transparent sound available of any speaker in its class.

Black Series speakers are available in AI a Cart and 2-way and 3-Way component systems allowing users to create virtually any configuration of system applications for the ultimate listening experience. All component systems include specifically designed audiophile grade adjustable crossover networks with hand picked audiophile grade components and ARC Audio's own driver specific modular Crossover design allowing users and installers a much simpler solution for installation over the competition's large single unit chassis crossover designs.

Experience the speaker revolution known as Black Series at an Authorized Brick and mortar location near you or online exclusively at [www.arcaudio.com](http://www.arcaudio.com).

# ***BLACK CROSSOVER FEATURES***











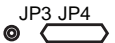





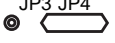

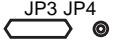





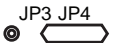

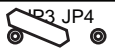

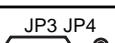

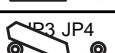
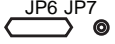





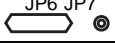

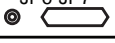



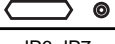

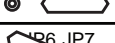



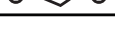

The ARC Audio Black component system includes a very sophisticated, Vari-Point or Variable Point crossover system. This system allows significantly more tuning flexibility than the common component system. Vari-Point offers a wide range of crossover points for each speaker ranging from 2KHz to 5.9KHz. This 1+ octave range allows the Black to perform its best in any application or vehicle insuring perfect audio reproduction every time. The crossovers are shipped preset at 2.6KHz on the LPX and 3.2KHz on the HPX. This is a good starting point and in many cases will require no further adjustments however if you feel the need to make changes to the crossover point please refer to the CROSSOVER POINT JUMPER SETUP chart.

Warning: If the crossover point select for the LPX is higher than the HPX your amplifier will see a significant drop in ohm load.

Like the LPX and HPX the MBX offers multiple crossover points. This system offers further flexibility when run a 3-Way component system. The MBX is simply a 2-Way highpass and lowpass crossover. The lowpass or MIDBASS output is intended to run the midbass woofers directly. The highpass or MID output is designed to be used with the LPX to achieve the necessary bandpass for the Mid Range driver.

To improve ease of installation each speaker is supplied with its own crossover which needs to be wire independently to the amplifier. These crossovers can be located anywhere that is convenient for you application. Locating one or more of the crossovers inside the door is an option however please insure it is mounted in an area that will stay dry.

## ***CROSSOVER POINT JUMPER SETUP***

<b>HPX</b>			
5.9K LINKWITZ RILEY Q=.49			
5.1K Q=.42			
5.0K BESSEL Q=.585			
4.2K Linkwitz Riley Q=.501			
3.85K Q=.319			
3.8K BUTTERWORTH Q=.763			
3.2K Q=.312			
3.2K BUTTERWORTH Q=.653			
2.5K LINKWITZ RILEY Q=.496			
<b>LPX</b>			
4.85K LINKWITZ RILEY Q=.487			 
4.1K Q=.416			 
4.0K BESSEL Q=.586			 
3.4K LINKWITZ RILEY Q=.501			 
3.1K BUTTERWORTH Q=.762			 
2.6K BUTTERWORTH Q=.651			 
2.6K BUTTERWORTH Q=.651			 
2.6K Q=.381			 
2.0K LINKWITZ RILEY Q=.651			 
<b>MBX HP</b>			
380Hz LINKWITZ RILEY Q= .478			
270Hz BUTTERWORTH Q=.676			
220Hz BUTTERWORTH Q=.828			
<b>MBX LP</b>			
380Hz LINKWITZ RILEY Q= .478			
270Hz BUTTERWORTH Q=.676			
220Hz BUTTERWORTH Q=.828			

# CROSSOVER JUMPER LOCATIONS

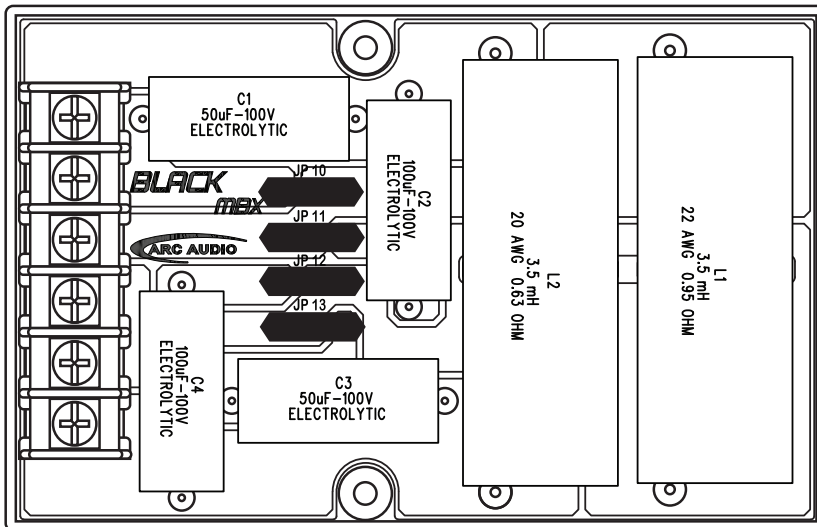
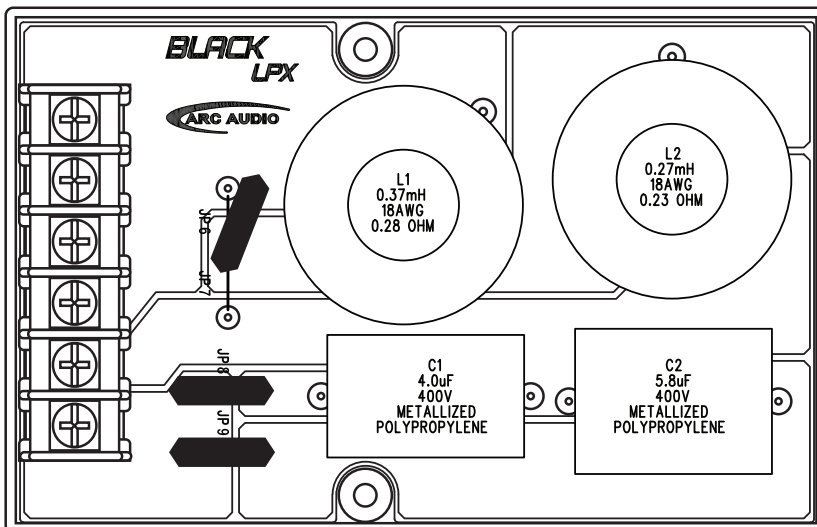
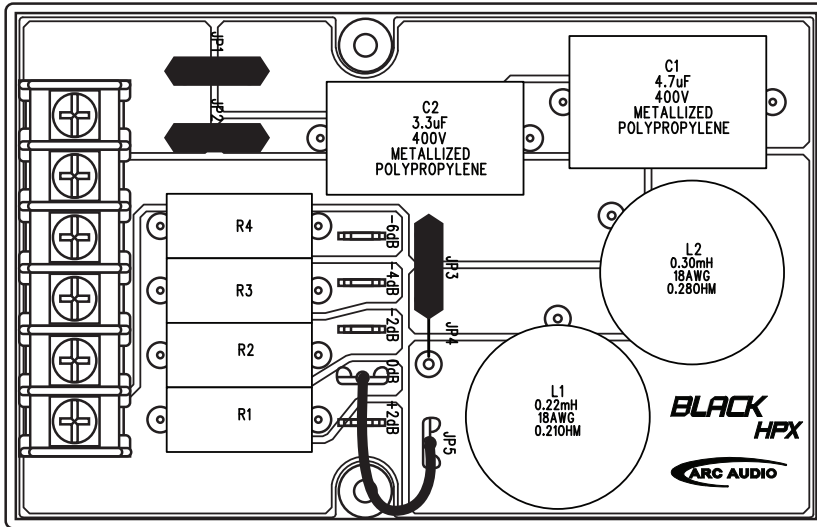

# 2-WAY SYSTEM

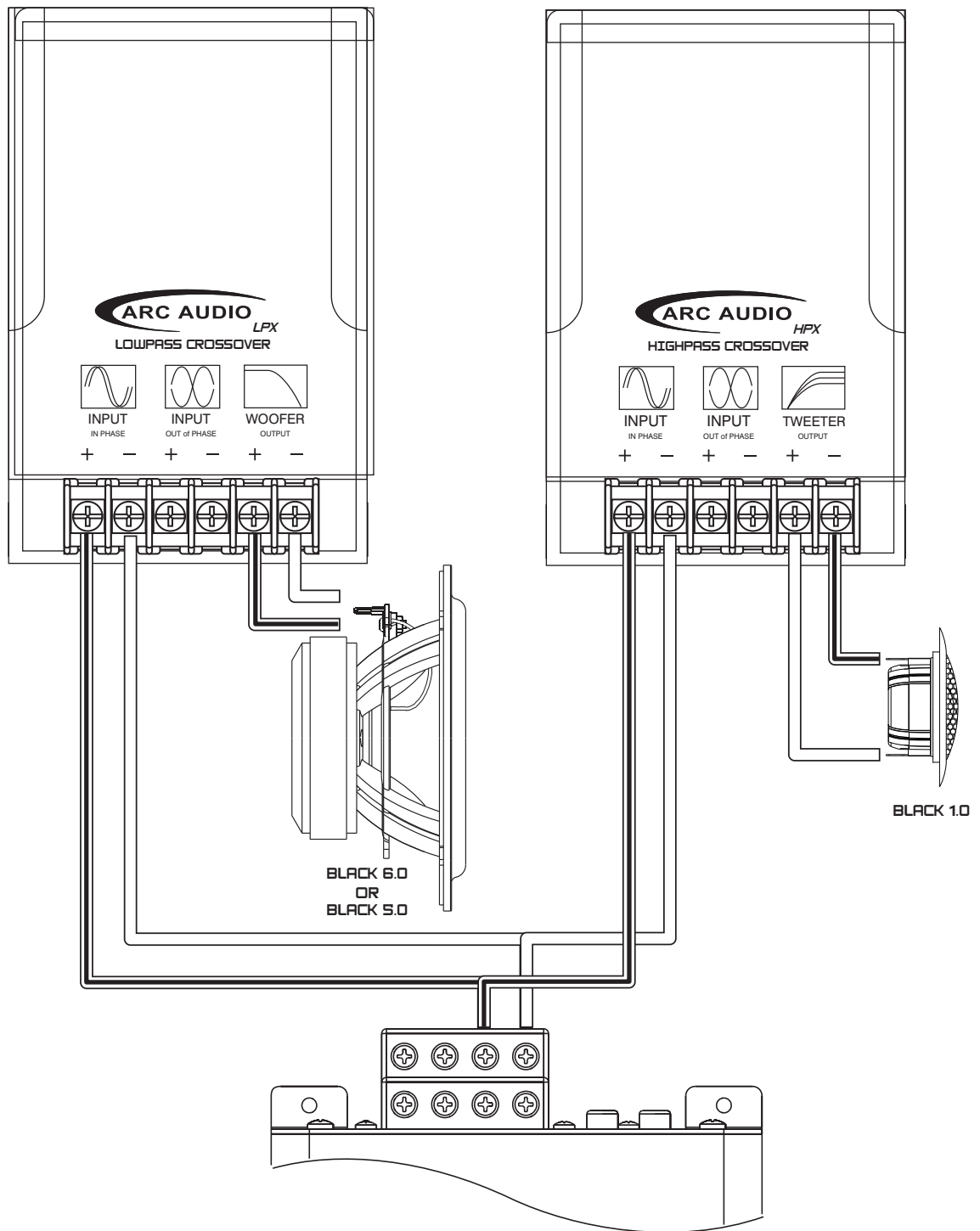

# 2-WAY SYSTEM BI AMPLIFIED

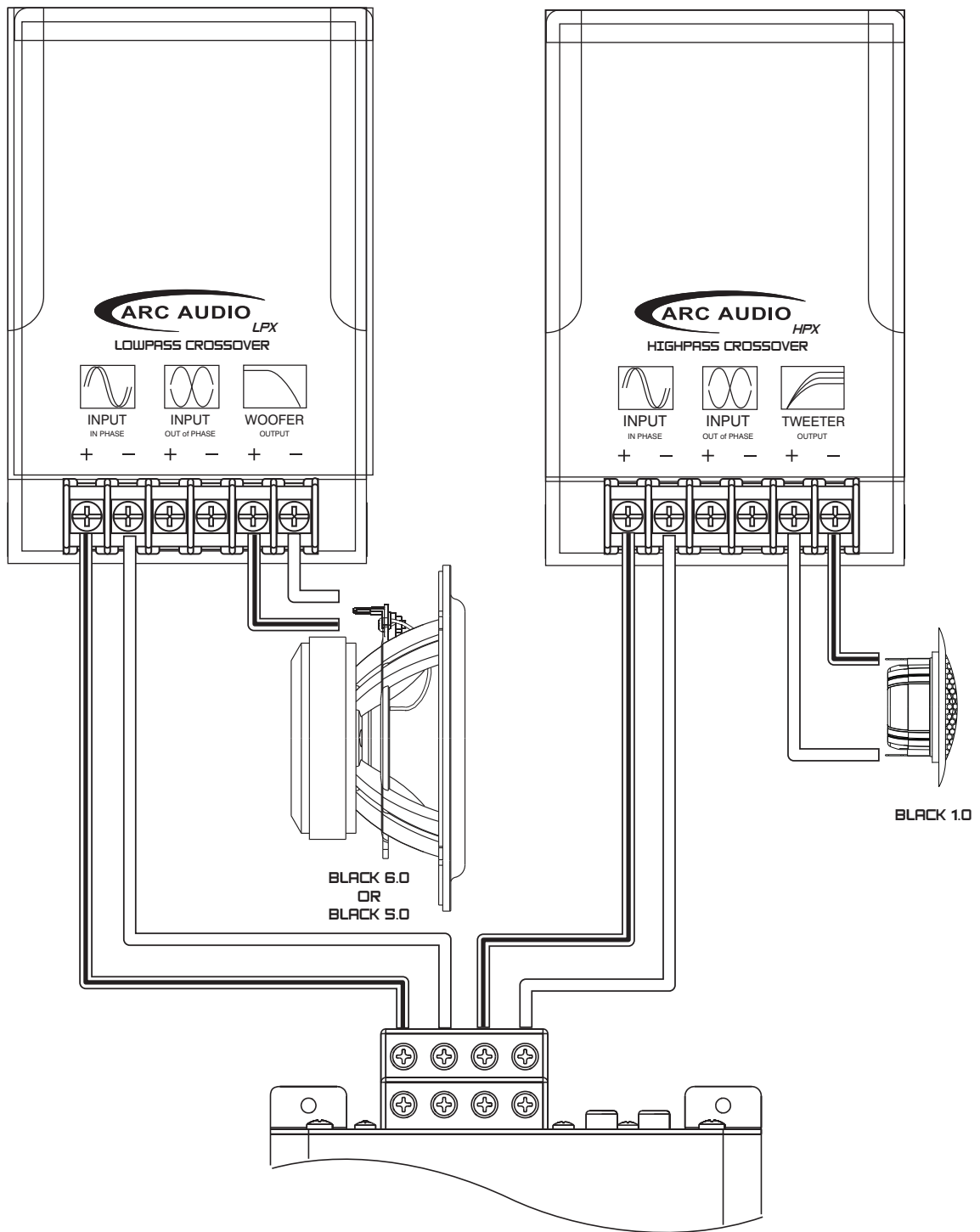

# 3-WAY SYSTEM

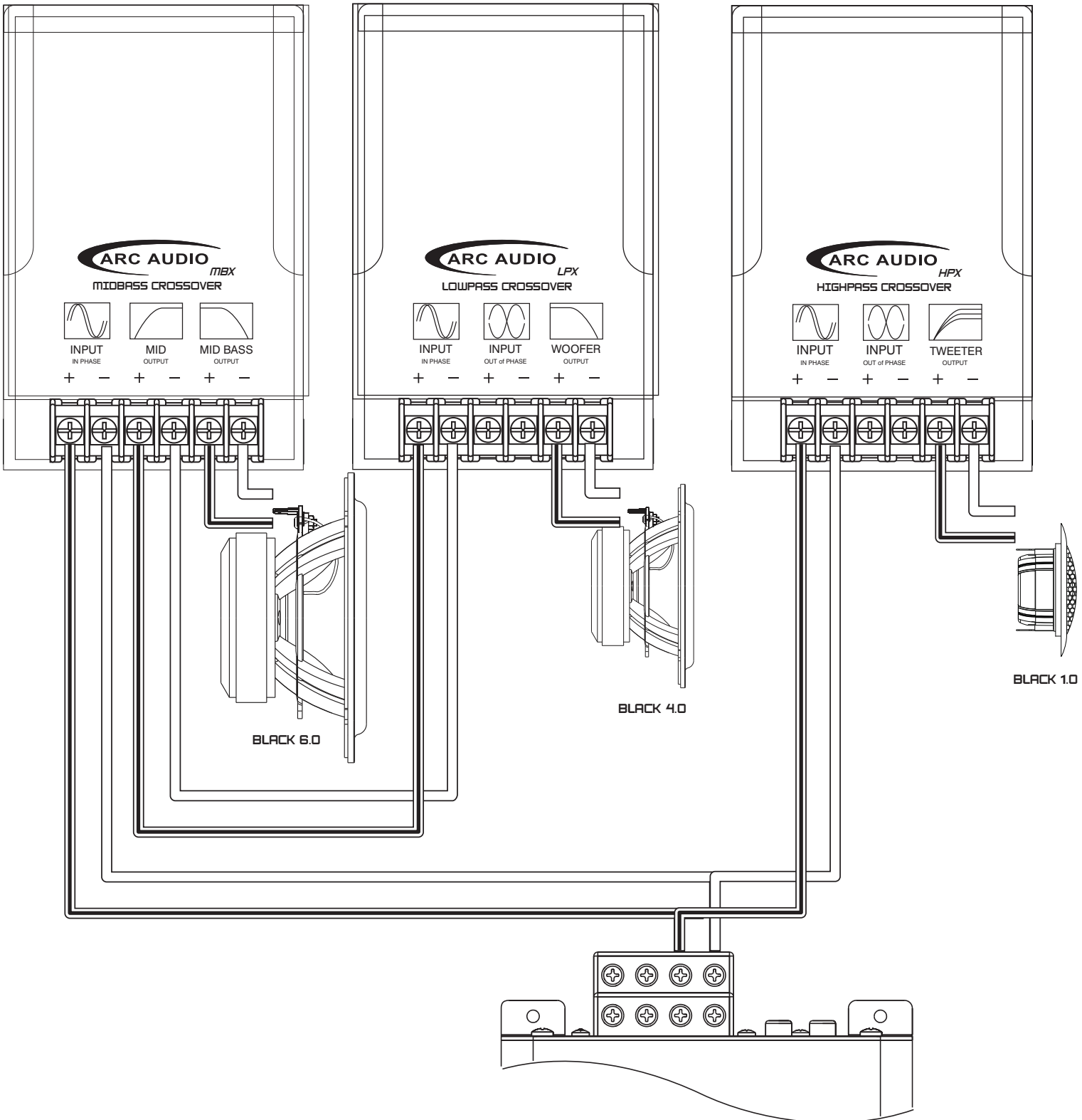





# BLACK 4.0 SPECIFICATIONS AND PARAMETERS

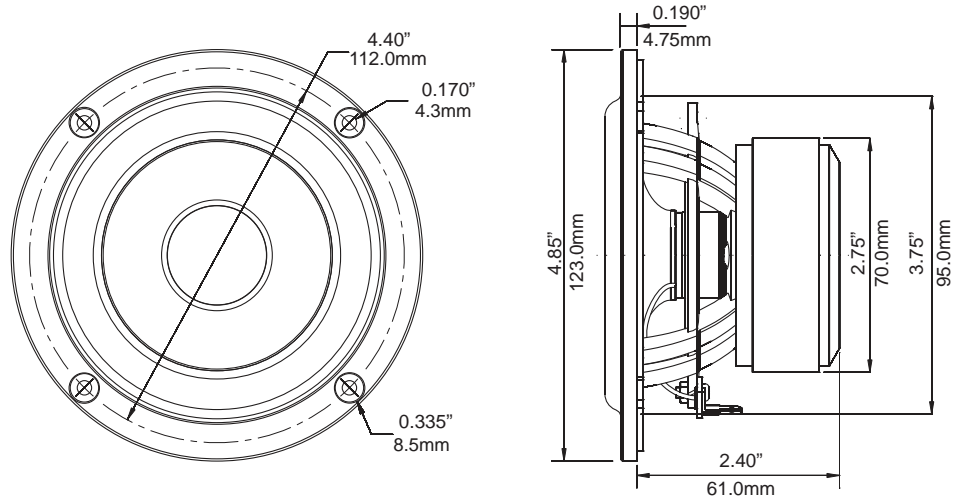

BLACK 4.0		
Fs	58.9	Hz
Re	3.1	Ohms
Qms	3.38	
Qes	0.50	
Qts	0.43	
Mms = gr	5.0	Grams
BL	3.4	

BLACK 4.0		
SPL	85.2	dB 1 watt @ 1 meter
VAS = L	5.15	Liters
Le	1.4	Millihenry
Sd = cm <sup>2</sup>	50.3	Square Centimeters
Xmax	5MM	
Power Handling	120 W	Music
Power Handling	60 W	RMS

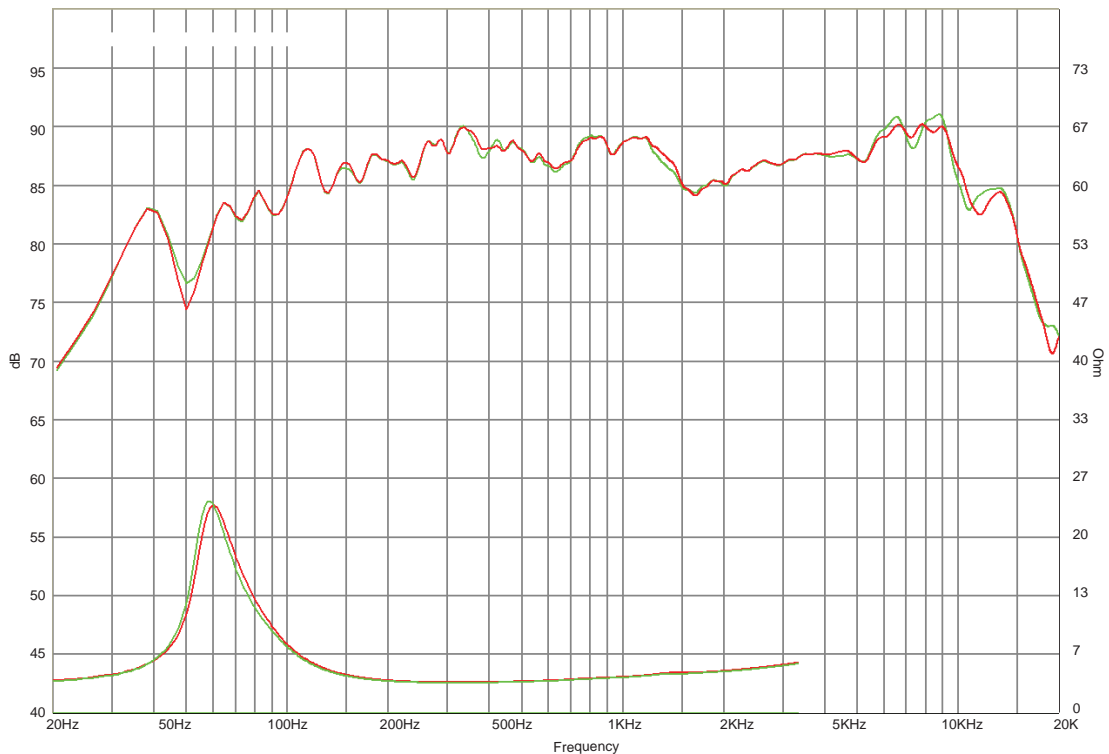

# BLACK 5.0 SPEAKER SPECIFICATIONS AND PARAMETERS

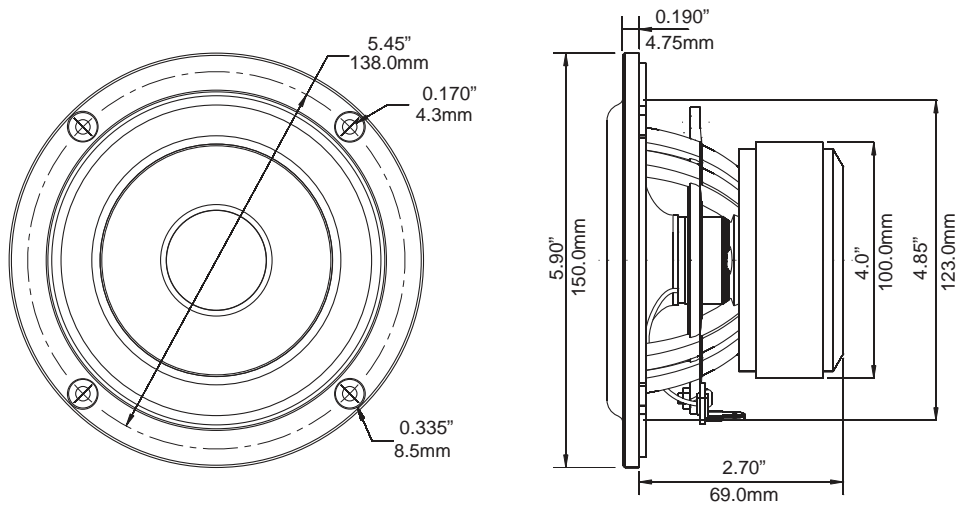

**BLACK 5.0**

Fs	41.5	Hz
Re	3.1	Ohms
Qms	5.52	
Qes	0.37	
Qts	0.36	
Mms = gr	9.2	Grams
BL	4.5	

**BLACK 5.0**

SPL	86.5	dB 1 watt @ 1 meter
VAS = L	14.9	Liters
Le	.12	Millihenry
Sd = cm2	81.7	Square Centimeters
Xmax	5MM	
Power Handling	150 W	Music
Power Handling	75 W	RMS

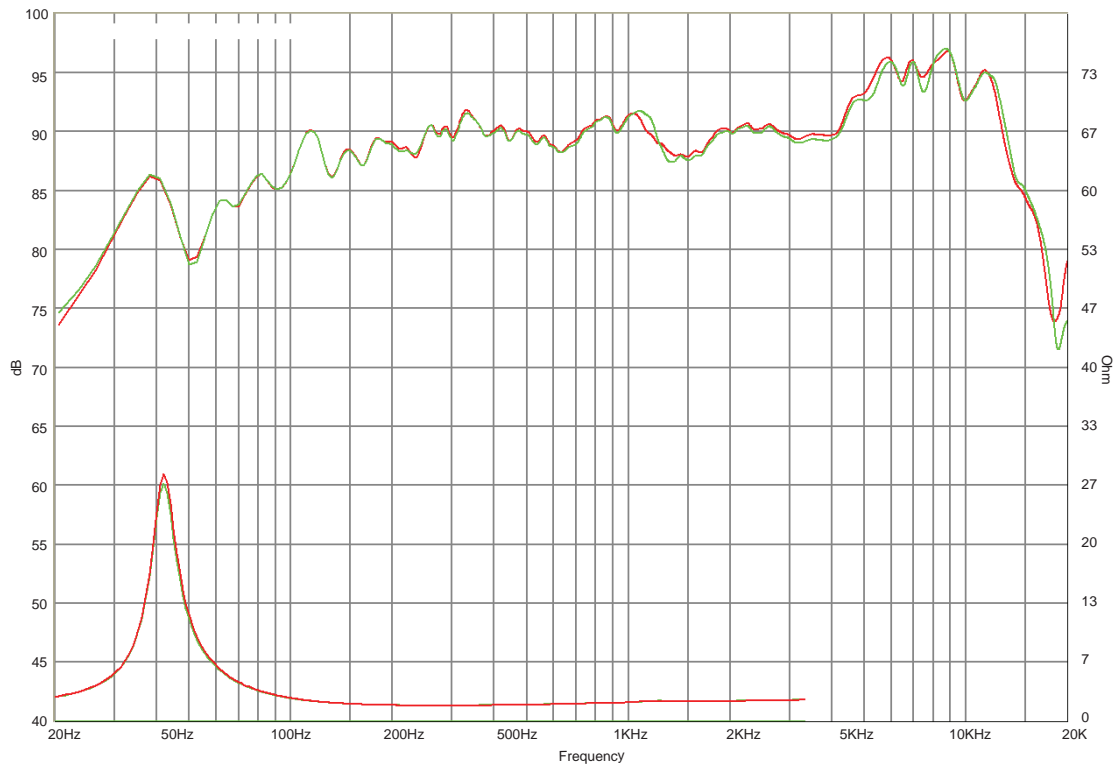

# BLACK 6.0 SPEAKER SPECIFICATIONS AND PARAMETERS

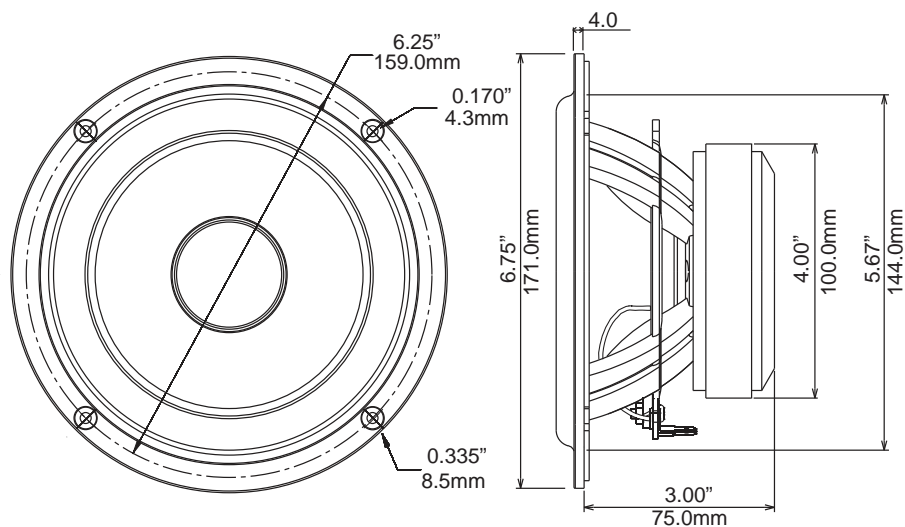

BLACK 6.0			BLACK 6.0		
Fs	44.4	Hz	SPL	88	dB 1 watt @ 1 meter
Re	3.1	Ohms	VAS = L	20.7	Liters
Qms	5.77		Le	.13	Millihenry
Qes	0.46		Sd = cm2	119	Square Centimeters
Qts	0.43		Xmax	5.5MM	
Mms = gr	12.3	Grams	Power Handling	200 W	Music
BL	4.8		Power Handling	100 W	RMS

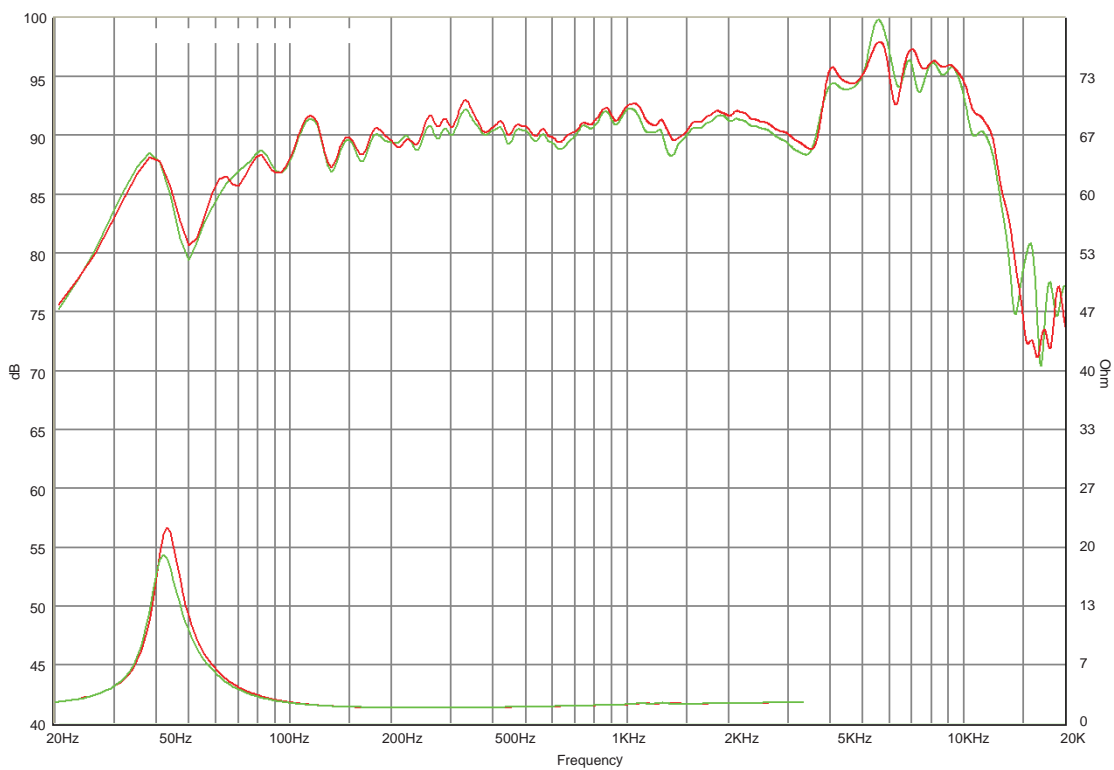

# BLACK 1.0 SPEAKER SPECIFICATIONS AND PARAMETERS

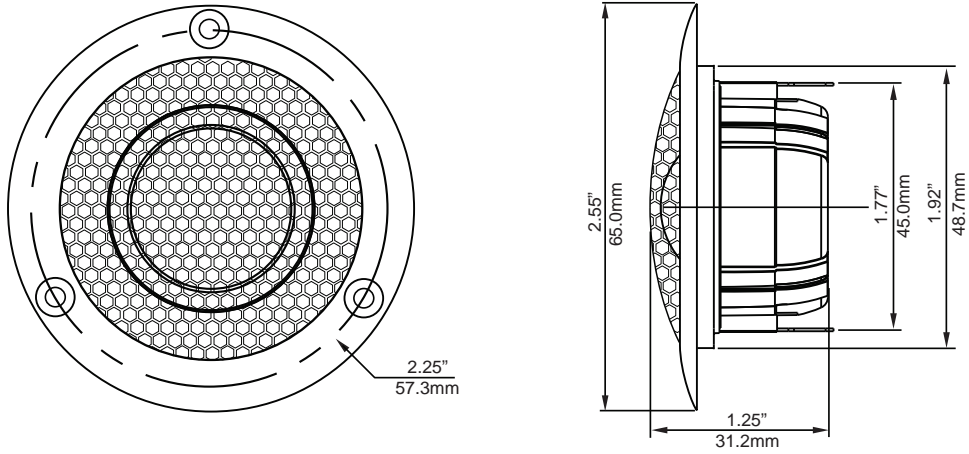

## BLACK 1.0

Fs	950	Hz
Re	3.2	Ohms
SPL	92	dB 1 watt @ 1 meter
Power Handling	120 W	Music
Power Handling	60 W	RMS

# WARRANTY

## Note to International Customers-

For warranty and repair service outside of the USA, please send your product directly to your countries authorized Arc Audio distributor for your service needs. As a customer you do have the option to send your product directly back to the factory in the USA but you will be responsible for "ALL" shipping costs, taxes, and duties to and from the USA. Return shipping charges and fee's must be paid by Credit Card with a signed credit card authorization form prior to the return shipment. This includes shipping cost, customs fee's, duties, local and government import/export tax's, broker's fee's and any other misc. fee's that could be added by your local government or other international agencies. International warranty shipments will not be accepted without a proper return authorization number and/or sales receipt documentation.

ARC AUDIO warrants all new products against defects in material and workmanship for a period of ONE (1) YEAR from the original date of purchase from an AUTHORIZED ARC AUDIO RETAILER.

This warranty is not transferable and applies only to the original retail purchaser of the product from an authorized ARC AUDIO retailer. Upon inspection by ARC AUDIO should services be necessary under this warranty for any reason due to manufacture defects ARC AUDIO will, at its sole discretion, repair or replace the defective product with new or similar conditioned product at no charge.

**THIS WARRANTY DOES NOT COVER INSTALLATION OR DAMAGE RESULTING FROM ACCIDENT, MISUSE, ABUSE, IMPROPER WIRING, OPERATION OUTSIDE OF UNIT OUTSIDE OF MANUFACTURES SPECIFICATIONS, OR AGAINST INSTRUCTIONS IN OWNERS MANUAL. IN ADDITION ANY PRODUCT THAT HAS BEEN OPENED, TEMPERED WITH OR MODIFIED, OR IF ANY SERIAL NUMBERS HAVE BEEN REMOVED OR ALTERED WILL NOT BE COVERED BY ANY PART OF THE MANUFACTURES WARRANTY.**

All warranty returns should be sent to ARC AUDIO freight prepaid and must be accompanied by proof of purchase (a copy of the original sales receipt). Direct returns from consumers or non-authorized retailers will be refused unless specifically authorized by ARC AUDIO with a valid return authorization number.

All warranty returns must be packed in original packaging and be accompanied by a copy of the original printed sales receipt. Product damaged in shipment due to improper packaging will not be covered under this warranty and the customer or retailer will be charged full cost to repair the specific piece of product back to a like new or similar condition.

In no event will ARC AUDIO be liable for incidental, consequential, or other damages resulting from the use of this product, this includes but is not limited to, damage of hearing, property or person, damage based upon inconvenience or on loss of use of the product, and to the extent permitted by law, damages for personal injury. This warranty gives you specific legal rights, and you may have other rights, which vary from state to state. This warranty applies to products sold and used in the United States of America. In all other countries please contact your distributor.

The following are examples of what is not covered under Arc Audio's warranty policy-

Any Product that is missing or has altered/damaged Serial numbers

Any Product that has been damaged as a result of physical abuse

Any Product that has been modified or altered from its original form or design and/or repair has been attempted by unauthorized repair facilities.

Any product that has been previously owned by another use and was sold private party. (Arc Audio's warranty policy is not transferable to third party or second hand users)

Any product purchased from ANY form of online marketplace (web sites, EBay or similar auction site, web site talk forum sales, etc)

Any product not purchased at a brick and mortar authorized store front location.

Any Speaker or Subwoofer than has been damaged to over-powering causing burnt voice coils and/or mechanical failures such as ripped spiders or surrounds.

Product that has not been installed as per manufacture recommendations including wiring and installation related damage to product.

Cosmetic damage due to installation, shipping and handling, and normal wear and tear.

Arc Audio will not be responsible for any product that has any kind of custom finish or customized cosmetic additions that differs from the original form as manufacture from Arc Audio.

Products damaged by "Acts of God" (Flood, Fire, Infestations, etc.)

ARC Audio  
4719 Greenleaf Cir. #4  
Modesto, CA 95356  
Ph. 209-543-8706

